

Hydrapak Hydraulic Oil Cooler

Market

The Hydrapak is a lightweight, compact oil cooler combining the reservoir, filter, control and safety equipment required in a hydraulic system within one assembly. This replaces large, heavy oil tanks and separate ancillaries allowing increased payloads, fast installation and lower running costs.

Why use Oil Coolers

The two ways of cooling the oil (heated by inefficiencies in hydraulic circuits) are:

1. Use enough oil so that the heat created will never become too great during a single discharge.
2. Cool the oil so that the heat created will always be dissipated.

The most effective method is the second one which is smaller, allows the system to operate for unlimited periods, weighs considerably less (allowing the payload of the vehicle to be larger) and uses less oil (running costs).

Specification

Mounting

The compact shape and size of the cooler make it ideal for mounting in small spaces on any chassis.

Heat dissipation

All variations can dissipate a maximum of 8 kW of heat for a 40°C temperature rise in a 45°C ambient automatically (without adjustment of fan speeds).



The Standard Package

The Hydrapak is available in two pressure variations (200 and 300 bar maximum), and three flow versions (60, 100 and 140 litre/min).

All variations contain the following integral equipment:

- Oil reservoir (11 litres)
- Cooling fan, radiator and mini hydraulic motor
- Relief valve
- 10 micron oil filter (return)
- Filter / radiator bypass valve
- Oil level sight glass
- Filter block indicator
- Suction elbow and pipe kit

After mounting, the installer simply connects the cooler to the hydraulic pump and motor with no sizing/arranging of any other equipment.



Hydraulic Oil Coolers

Hydrapak

HYDRAPAK OIL COOLER

Options

The Hydrapak is available in two pressure variations (200 and 300 bar maximum) and three flow versions (60, 100, 140 litre/min).

Dimensions

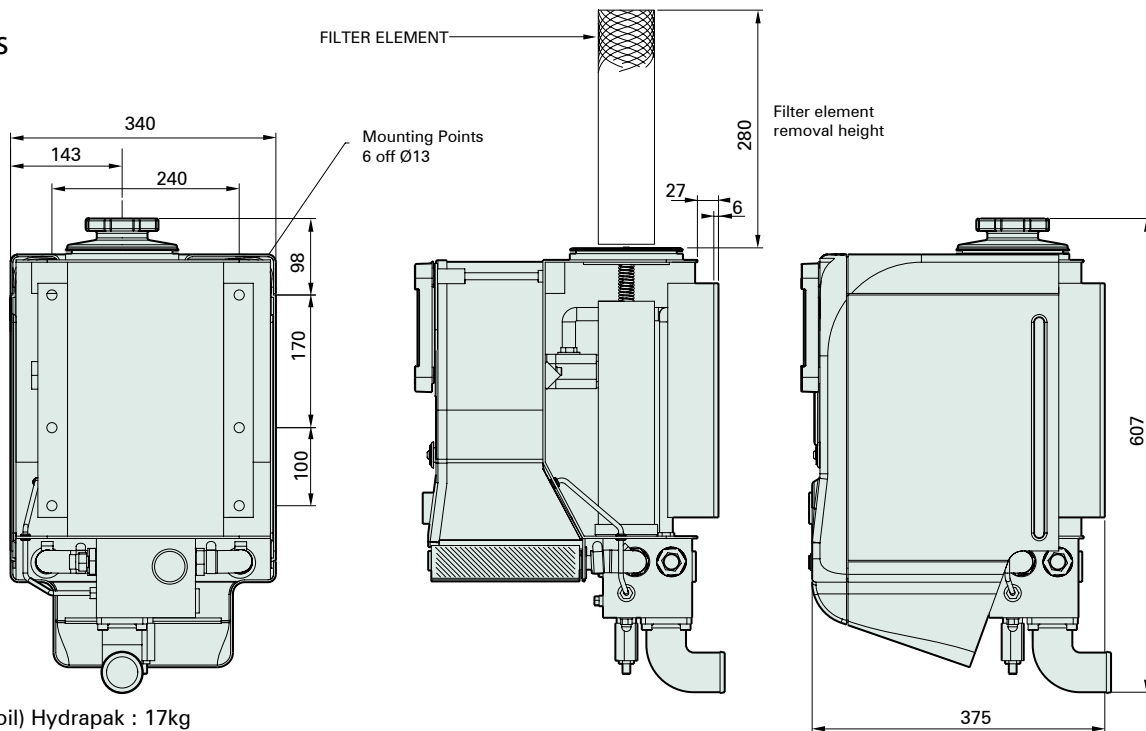

Weight (without oil) Hydrapak : 17kg

Installation and benefits of hydraulic drive systems

The installation drawing below shows a typical PTO driven hydraulic system incorporating the Hydrapak surrounded by some of the benefits in using hydraulic systems.

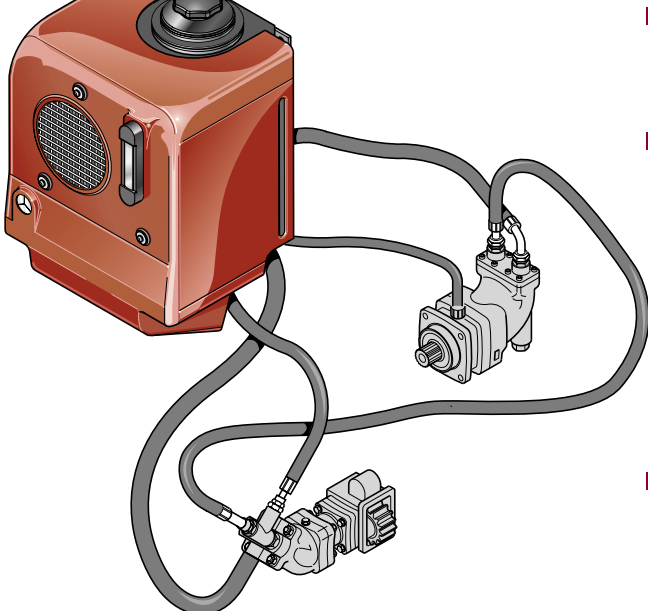
- 
- Reduces the risk of cavitation in cargo pumps by allowing them to be mounted in the ideal position.
 - Trailer mounted cargo pumps allow permanent connection of tank hoses, eliminating the risk of spillage.
 - Lower, quieter engine speeds can be more easily used.
 - Prevents shock loading of the gearbox.
 - Multi-pump and compressor systems can be driven from one PTO.
 - Available spaces on chassis are much more usable.

CONTACT YOUR GARDNER DENVER REPRESENTATIVE

CONTACT HEAD OFFICE



PO Box 178, Springmill Street, Bradford, West Yorkshire,
BD5 7YH, England

Tel: +44 (0) 1274 718100 Fax: +44 (0) 1274 718101

Sales: +44 (0) 1274 718160

Web: www.eu.gardnerdenver.com e-mail: drumsales@eu.gardnerdenver.com