

HYDRAPAK OIL COOLER

Options

The Hydrapak is available in two pressure variations (200 and 300 bar maximum) and three flow versions (60, 100, 140 litre/min).

Dimensions

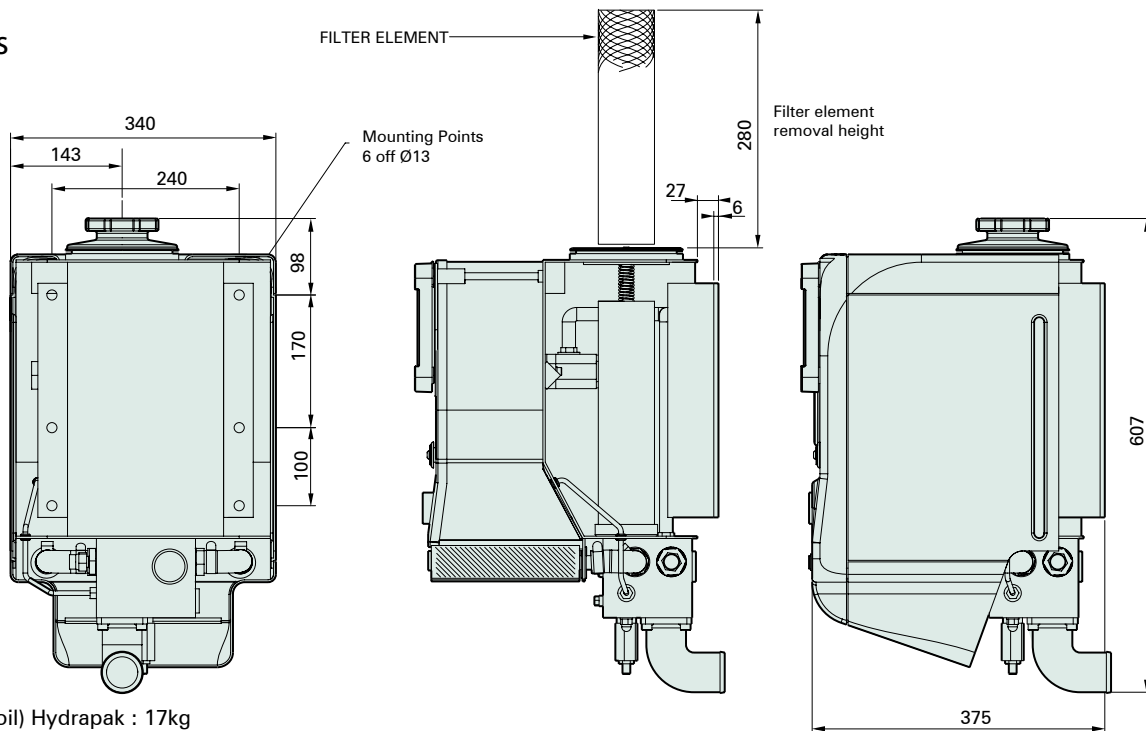

Weight (without oil) Hydrapak : 17kg

Installation and benefits of hydraulic drive systems

The installation drawing below shows a typical PTO driven hydraulic system incorporating the Hydrapak surrounded by some of the benefits in using hydraulic systems.

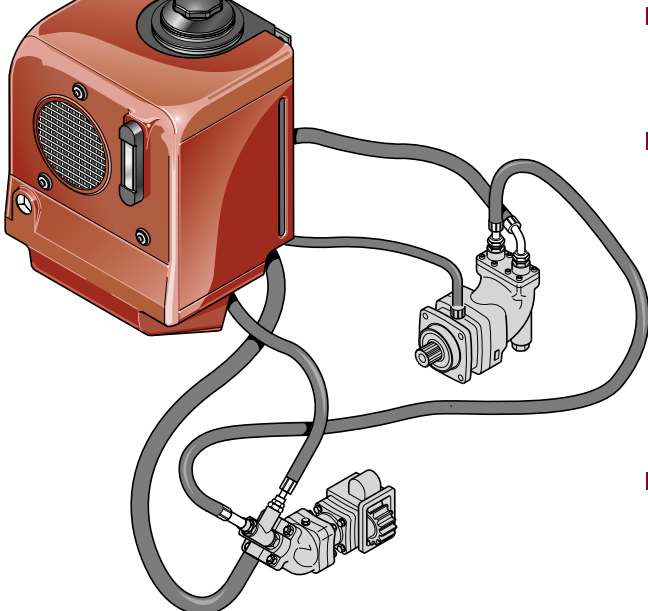
- 
- Reduces the risk of cavitation in cargo pumps by allowing them to be mounted in the ideal position.
 - Trailer mounted cargo pumps allow permanent connection of tank hoses, eliminating the risk of spillage.
 - Lower, quieter engine speeds can be more easily used.
 - Prevents shock loading of the gearbox.
 - Multi-pump and compressor systems can be driven from one PTO.
 - Available spaces on chassis are much more usable.

CONTACT YOUR GARDNER DENVER REPRESENTATIVE

CONTACT HEAD OFFICE



PO Box 178, Springmill Street, Bradford, West Yorkshire,
BD5 7YH, England

Tel: +44 (0) 1274 718100 Fax: +44 (0) 1274 718101

Sales: +44 (0) 1274 718160

Web: www.eu.gardnerdenver.com e-mail: drumsales@eu.gardnerdenver.com